

REVISIONS			
LTR	DESCRIPTION	DATE	APPROVED
A	FIRST RELEASE	01-25-05	

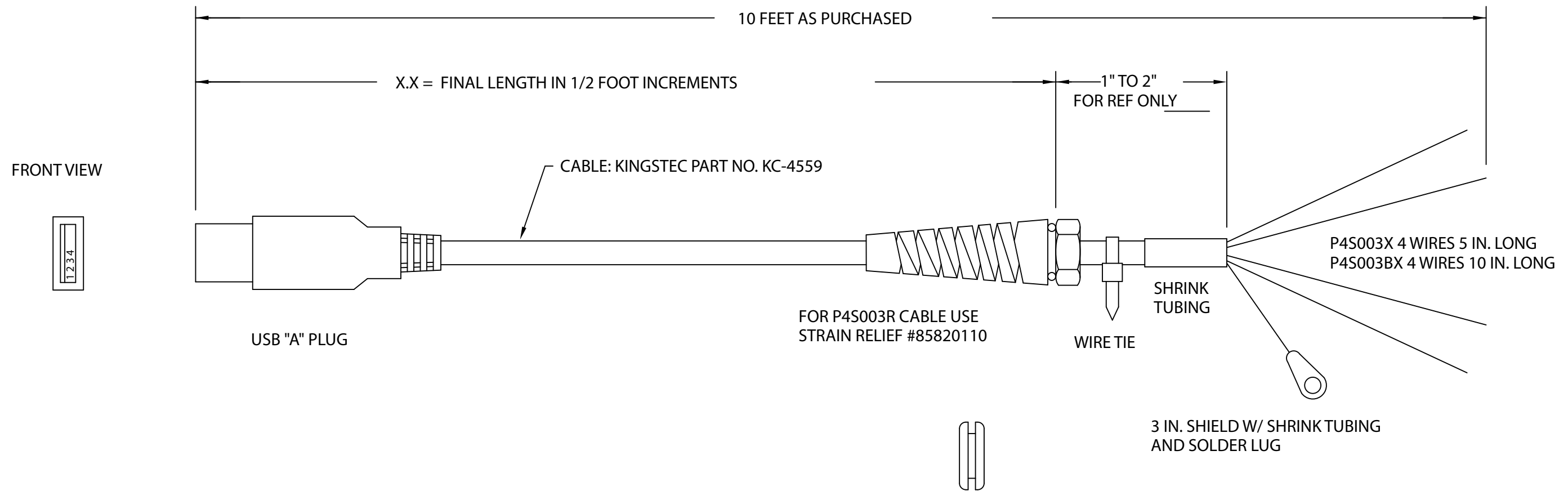

PIN NO.	COLOR	FUNCTION
1	RED	+5 VOLTS
2	WHITE	D-
3	GREEN	D+
4	BLACK	COMMON
SHELL	—	SHIELD

UNLESS OTHERWISE SPECIFIED: DIM AND TOL APPLY AFTER FINISH	ORIG DATE 01-25-05
DIMENSIONS ARE IN INCHES FRACTIONS DECIMALS ANGLES .XX ±.005 ±1/2°	DRAFTER S.SZERSZEN
MACH CORN-.005 TO .015 R OR CHAM SH MATL-BREAK EDGES .005 MAX R	CHECKER
ALL MACHINED SURFACES TO BE MATERIAL	APPROVED
	APPROVED
	APPROVED
	DESIGN ACTIVITY APPROVAL
FINISH	ECN

CTI ELECTRONICS CORP.	
STANDARD USB CABLE	
SIZE B	P4S003X-X.X
SCALE 1/1	WT - SHEET OF 1

THESE DRAWINGS AND SPECIFICATIONS ARE THE PROPERTY OF CTI ELECTRONICS CORP, INC., AND ARE ISSUED IN STRICT CONFIDENCE, AND SHALL NOT BE REPRODUCED, OR COPIED, OR USED AS THE BASIS FOR THE MANUFACTURE OR SALE OF EQUIPMENT WITHOUT PRIOR WRITTEN PERMISSION

MOD KIT	NEXT ASS'Y	QTY	USED ON	MODEL
APPLICATION				