

PS/2 HEADER	REF. CTI CABLE COLORS!
① CLOCK	YELLOW
② DATA	BLACK
③ +5VOLTS	RED
④ COMMON	GREEN

USB HEADER	
① RED	(+5V)
② WHITE	(D-)
③ GREEN	(D+)
④ BLACK	(COM)

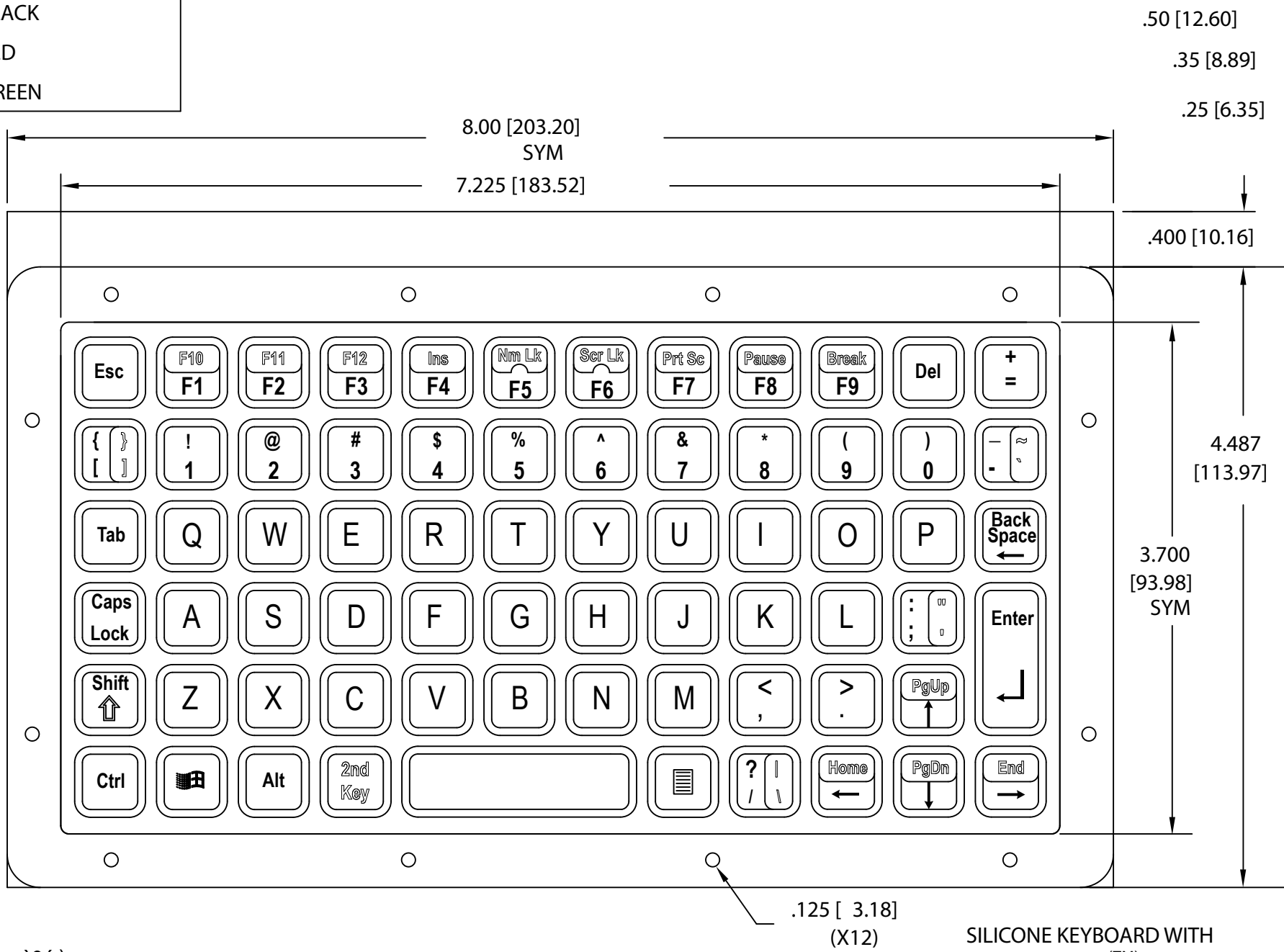

ORDERING INFORMATION:

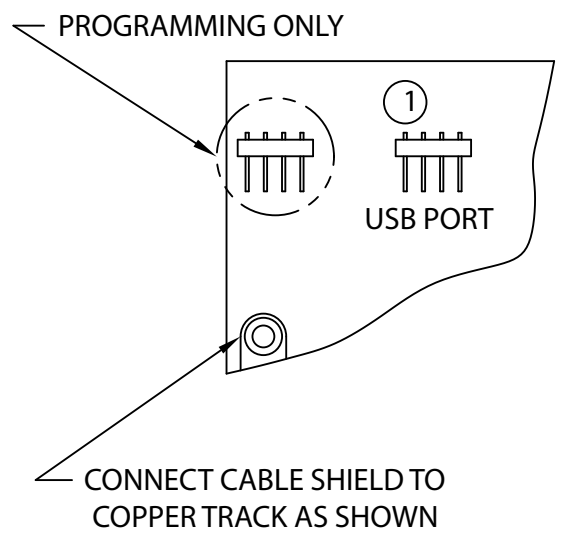
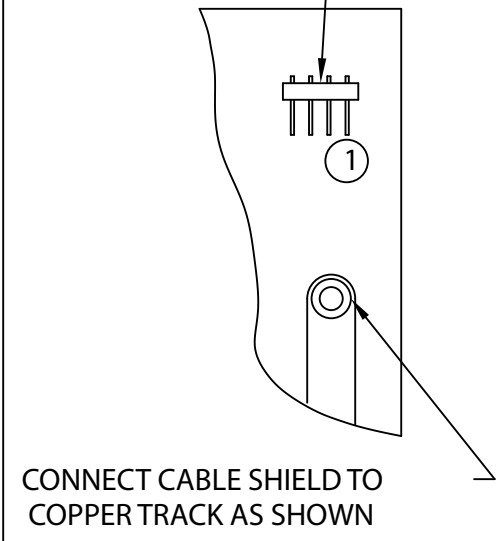
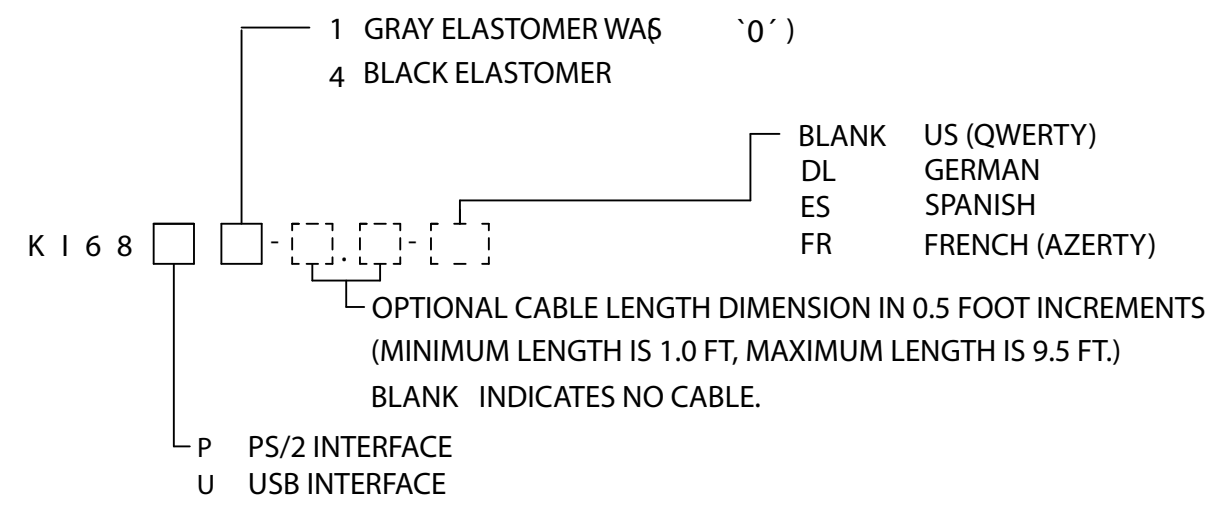

SPECIFICATION:

TEMPERATURE: -40°C TO +80°C
 SEALING: NEMA 4 (IP66)
 SHOCK: 40G (N) 11 msec. per MIL-STD-810
 WEIGHT: KEYBOARD WITH PCB: APPROX. 7 OZ. (198 GRAMS)
 9.5 FT. USB CABLE ONLY: APPROX. 2.8 OZ. (80 GRAMS)
 STANDARDS: ☑, ROHS, REACH, FCC CLASS B
 (WHEN PROPERLY INSTALLED IN A SHIELDED METAL ENCLOSURE)

SILICONE KEYBOARD WITH SYN-PROOF COATING

NOTE: DIMENSIONS ARE IN INCHES [MILLIMETERS]

CTI ELECTRONICS CORPORATION	
WWW.CTIELECTRONICS.COM	
OEM INDUSTRIAL KEYBOARD NEMA 4 (IP66) KI6800 SERIES	
761747	
APPROVED	DATE 02-10-16
SHEET 1 OF 2	DRAWN BY PSB

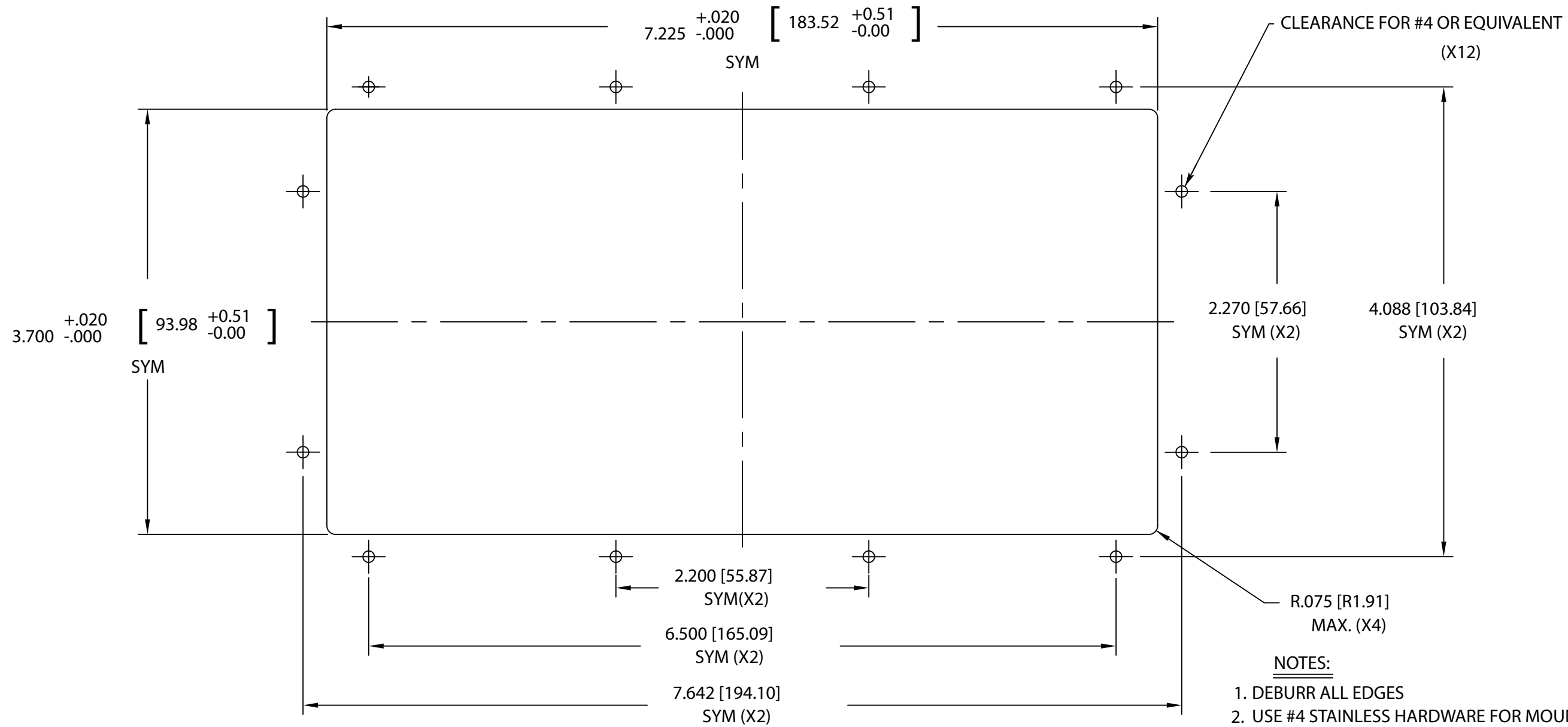

- NOTES:**
1. DEBURR ALL EDGES
 2. USE #4 STAINLESS HARDWARE FOR MOUNTING.
 3. TAKE 'ESD' PRECAUTIONS DURING INSTALLATION AS ELECTRONIC COMPONENTS ARE EXPOSED.

MOUNTING DETAIL

NOTE: DIMENSIONS ARE IN INCHES [MILLIMETERS]

CTI <u>ELECTRONICS CORPORATION</u> WWW.CTIELECTRONICS.COM	
OEM INDUSTRIAL KEYBOARD NEMA 4 (IP66) KI6800 SERIES	
761747	
APPROVED	DATE 02-09-16 DRAWN BY PSB
SHEET 2 OF 2	