

**ORDERING INFORMATION**

- 1 4-40 THREADED INSERTS
- 3 3MM THREADED INSERTS
- 0 STANDARD TWO AXES
- 6 SINGLE "Y" AXIS
- 9 DUAL AXIS NON-SIMULTANEOUS

- |              |               |
|--------------|---------------|
| <b>INPUT</b> | <b>OUTPUT</b> |
| 2 ±5V        | ±5V           |
| 4 +5V        | 0.5 TO 4.5V   |
| 5 +5V        | 0 TO 5V       |

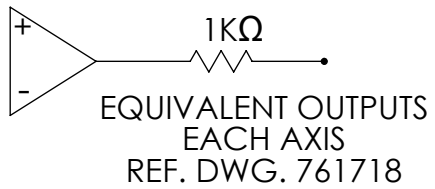

F [ ] [ ] [ ] [ ] A [ ] - N33

- 0 WITHOUT NEUTRAL SWITCH
- 1 NEUTRAL SWITCH (AVAILABLE ON +5V MODELS ONLY)
- Z CONFORMAL COATING
- R CONDUCTIVE BOOT (SILICONE)
- RF CONDUCTIVE BOOT AND FERRITE BEAD
- E WITHOUT DEADBAND
- G MAXIMUM COMPRESSION SPRING

**SPECIFICATIONS**

TEMPERATURE	-40°C TO +80°C
SEALING	NEMA 4 / IP66
WEIGHT	4 oz., 112 g
STANDARDS	CE, RoHS, REACH, IPC 610 CLASS II COMPLIANT

**OUTPUT HEADER DETAILS**

SOLDER TO HEADER OR USE "AMP" 6 POSITION CONNECTOR PART No. 1-87499-1 AND SIX PINS PART No. 102917-2, OR EQUIVALENT

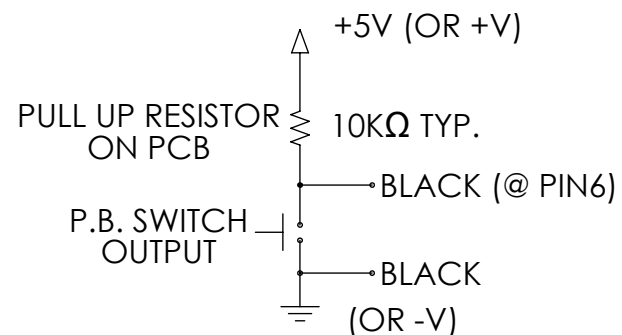
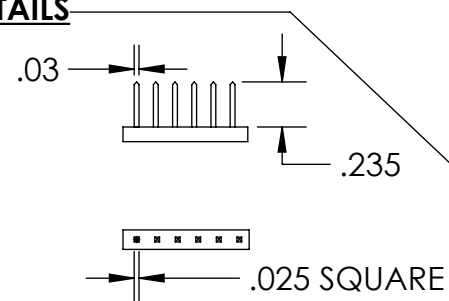

WITH NEUTRAL SWITCH OPTION, BLACK SWITCH WIRES ARE 8.0" LONG & DRY CONTACT ONLY

F1020	F1040 F1050
+5V	+5V
-5V	COMMON
X OUT	X OUT
COMMON	V REF.
Y OUT	Y OUT
PUSH BUTTON SWITCH OR OPTIONAL NEUTRAL SWITCH	

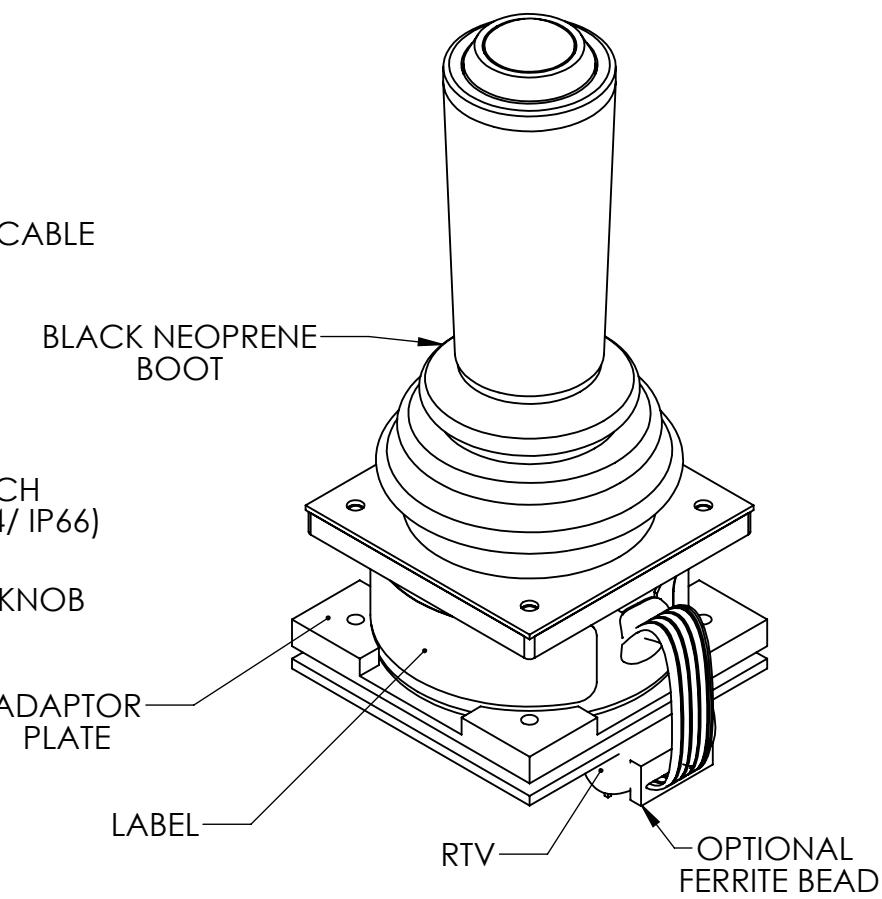
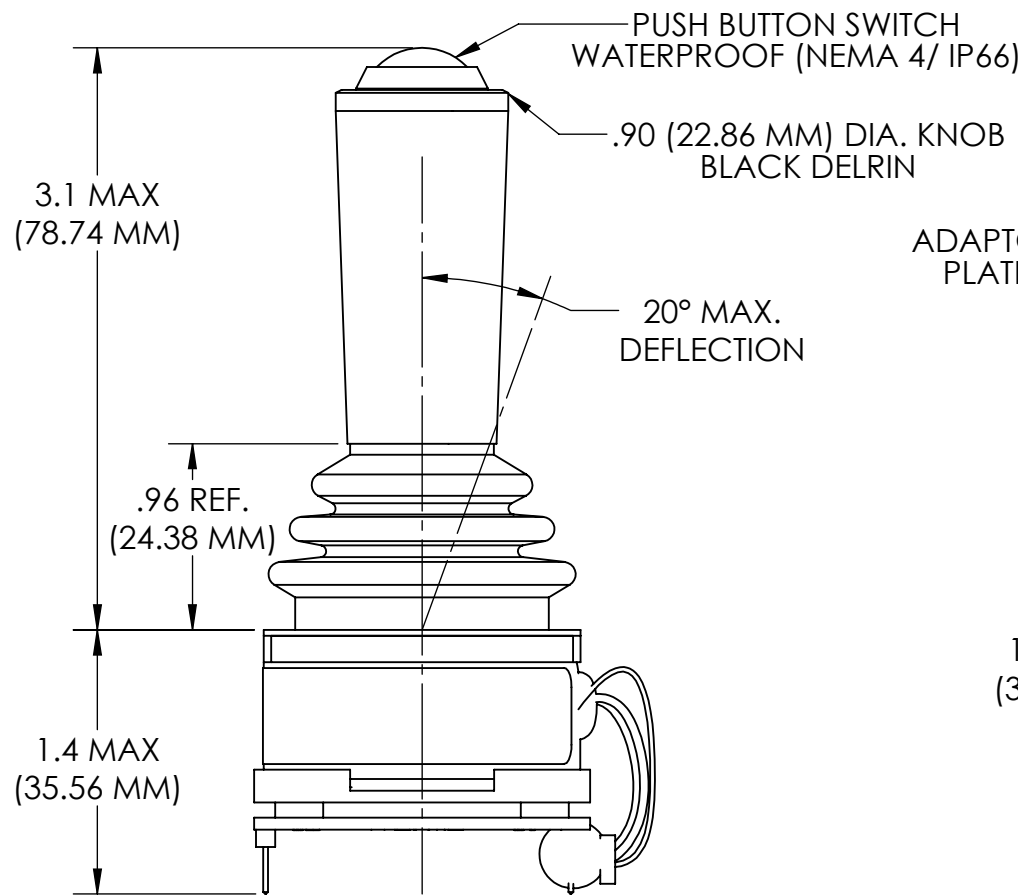
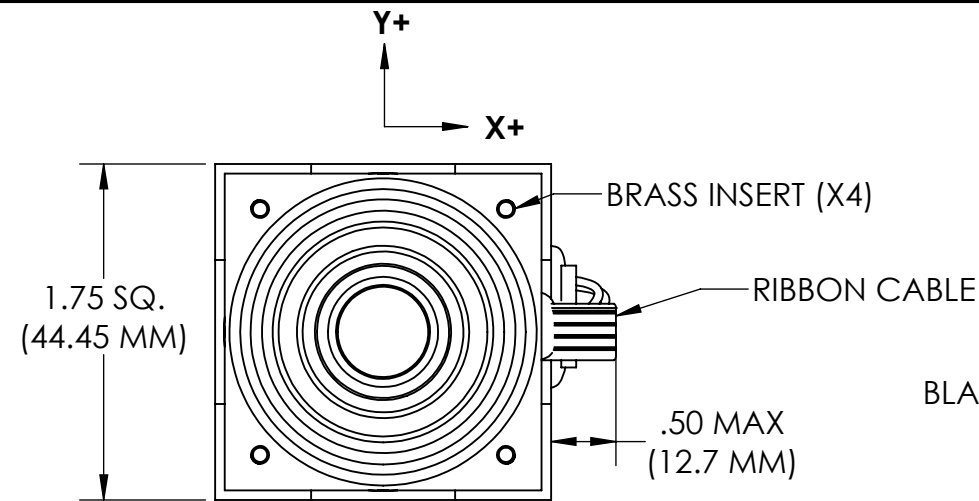

**MOUNTING DETAIL**

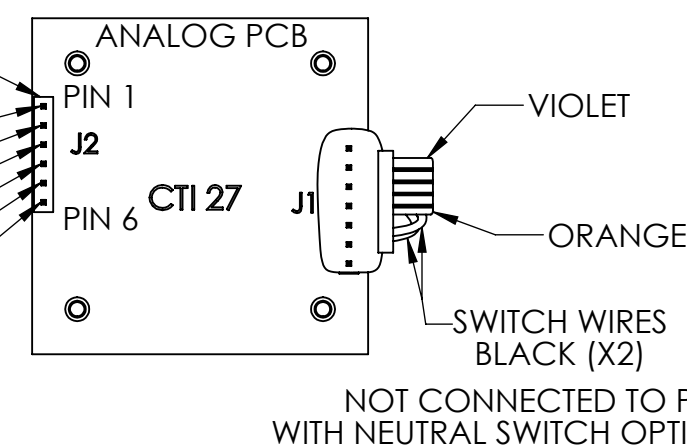
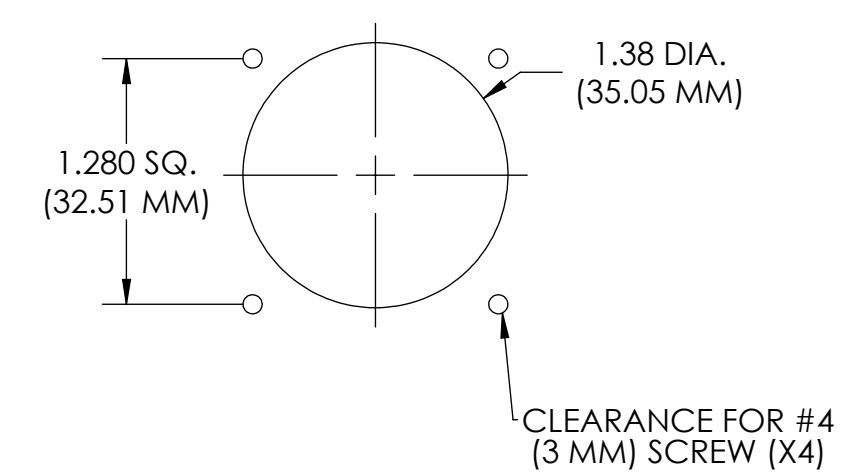

**CTI ELECTRONICS CORP.**  
WWW.CTIELECTRONICS.COM

NEMA 4 / IP66 INDUSTRIAL JOYSTICK F10X0A-N33 SERIES WITH ADAPTOR PLATE

**761856**

APPROVED: SHEET 1 OF 1 DATE 10-27-15 DRAWN BY: A.J.K.

COPYRIGHT 2015 CTI ELECTRONICS CORP. SPECIFICATIONS SUBJECT TO CHANGE WITHOUT NOTICE