

REVISIONS			
LTR	DESCRIPTION	DATE	APPROVED
A	FIRST RELEASE	12-26-07	

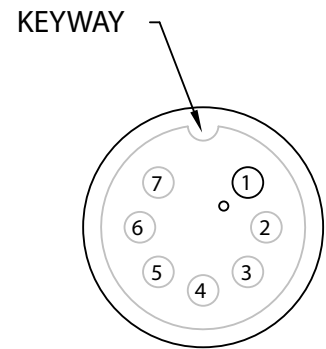

CONXALL #6282-7SG-513
FRONT VIEW

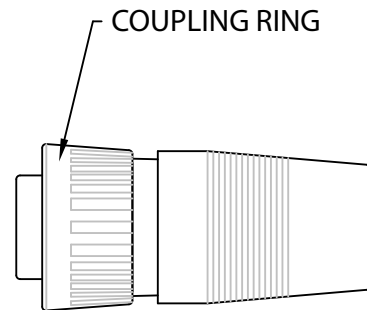

STRAIGHT MINI-CON-X 7#20 FEMALE
CABLE END OVERMOLDED (PVC)

KINGSTEC PART NO. KC-4559 (REF P4S003)
SUPPLIED BY "CTI", CUT LENGTH 10 FEET

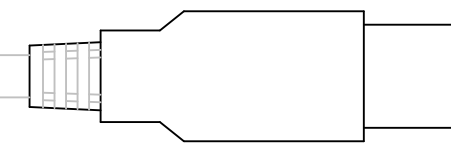

USB "A" PLUG

FRONT VIEW



PIN NO.	COLOR	FUNCTION
1	RED	+5 VOLTS
2	BLACK	COMMON
3		
4	—	SHIELD
5	GREEN	D+
6	WHITE	D-
7		

PIN NO.	COLOR	FUNCTION
1	RED	+5 VOLTS
2	WHITE	D-
3	GREEN	D+
4	BLACK	COMMON
SHELL	—	SHIELD

UNLESS OTHERWISE SPECIFIED: DIM AND TOL APPLY AFTER FINISH	ORIG DATE 12-26-07
DIMENSIONS ARE IN INCHES	DRAFTER S.SZERSZEN
FRACTIONS DECIMALS ANGLES	CHECKER
.XX ±.02 ±.005 ±1/2°	APPROVED
MACH CORN-.005 TO .015 R OR CHAM SH MATL-BREAK EDGES .005 MAX R	APPROVED
ALL MACHINED SURFACES TO BE	APPROVED
MATERIAL	APPROVED
FINISH	DESIGN ACTIVITY APPROVAL
	ECN

CTI ELECTRONICS CORP.	
USB CABLE WITH MOLDED CONXALL CONNECTOR REF. P0743	
SIZE B	P7S009-P0743
SCALE 1/1	WT - SHEET OF 1

MOD KIT	NEXT ASS'Y	QTY	USED ON	MODEL
APPLICATION				

THESE DRAWINGS AND SPECIFICATIONS ARE THE PROPERTY OF CTI ELECTRONICS CORP, INC., AND ARE ISSUED IN STRICT CONFIDENCE, AND SHALL NOT BE REPRODUCED, OR COPIED, OR USED AS THE BASIS FOR THE MANUFACTURE OR SALE OF EQUIPMENT WITHOUT PRIOR WRITTEN PERMISSION